



STELVIO

QUICK GUIDE

Dear Customer,

We would like to congratulate and thank you for choosing an Alfa Romeo.

This Quick Guide will provide you with the main indications and some recommendations for the use of your car.

This Quick Guide is not a substitute for reading the full Owner Handbook, which is available online, in greater depth.

The figures in this guide are only examples. This might imply that some details of the image do not correspond to the actual arrangement of your car.

After reading it, you are advised to keep this Quick Guide inside the car, for an easy reference and for making sure it remains aboard the car should it be sold.

In the attached Warranty Booklet you will also find the description of the Services that Alfa Romeo offers to its customers, the Warranty Certificate and the detail of the terms and conditions for maintaining its validity.

We are confident that these will bring you closer to your new car and make you appreciate the assistance provided by Alfa Romeo team.

Enjoy reading. Happy driving!

**The data contained in this publication should be understood as intended to guide you in the correct use of the car.
Alfa Romeo S.p.A. aims at a constant improvement of the vehicles produced. For this reason it reserves the right to make
changes to the model described for technical and/or commercial reasons.
For further information, contact an Alfa Romeo Dealership.**

ONLINE OWNER HANDBOOK

FCA is committed to protecting the environment and invites you to refer to the Complete Owner Handbook in digital form, via the QR code on this page or on the internet pages listed below.



Go to the **www.mopar.eu/owner** website and access your personal area.

The "Warranty and Maintenance" page contains all the information about your car and a link to access eLUM, where you will find all the details of the online Owner Handbook.

Alternatively, to access this information, go to the Internet website at **<http://aftersales.fiat.com/elum/>**.

The eLUM website is free and conveniently allows you to browse the on-board documents of all other models of the Group, among many other things.

Have a nice read and happy motoring!

CONTENTS

DASHBOARD	5	GREEN WARNING LIGHTS/ SYMBOLS	11	LEVERS ON THE STEERING WHEEL	16
AUTOMATIC DUAL-ZONE CLIMATE CONTROL SYSTEM	5	BLUE WARNING LIGHTS/ SYMBOLS	12	"ALFA DNA"TM SYSTEM	17
TAILGATE	6	WHITE WARNING LIGHTS/ SYMBOLS	12	MANUAL SOS CALL	17
OPENING THE TAILGATE FROM INSIDE	6	LANE KEEPING ASSIST SYMBOLS	12	CHILD RESTRAINT SYSTEMS	18
CLOSING THE TAILGATE FROM OUTSIDE	6	THE KEYS	12	PASSENGER'S FRONT AIRBAG AND CHILD RESTRAINT SYSTEMS	18
AUTOMATICALLY OPENING/ CLOSING THE ELECTRICALLY OPERATED TAILGATE IN "HANDS-FREE" MODE	6	ELECTRONIC KEY	12	DEACTIVATING/ACTIVATING THE PASSENGER SIDE AIRBAGS: FRONT AIR BAG AND SIDE BAG (where provided)	19
DISPLAY	6	IGNITION DEVICE	13	REPLACING A BULB	20
INSTRUMENT PANEL	7	EXTERNAL LIGHTS	13	DRIVING TIPS	20
"HERITAGE" DISPLAY	7	DIPPED BEAM HEADLIGHTS	13	CHANGING A WHEEL	20
"EVOLVED" DISPLAY	7	DAYTIME RUNNING LIGHTS (DRL) AND SIDE LIGHTS (Daytime Running Lights)	13	TYRE REPAIR KIT	23
"RELAX" DISPLAY	8	REAR FOG LIGHT	13	PRELIMINARY OPERATIONS	23
"Race" DISPLAY (Quadrifoglio versions)	8	PARKING LIGHTS	13	OPT1 KIT DESCRIPTION	23
WARNING LIGHTS AND MESSAGES	9	MAIN BEAM HEADLIGHTS	14	OPT2 KIT DESCRIPTION	24
INSTRUMENT PANEL DISPLAY FAILURE	9	DIRECTION INDICATORS	14	FUSES	28
RED WARNING LIGHTS/SYMBOLS ..	9	AUTO FUNCTION (Dusk sensor)	14	SCHEDULED SERVICING	29
AMBER WARNING LIGHTS/ SYMBOLS	9	TPMS (Tyre Pressure Monitoring System)	14	SERVICE SCHEDULE (2.9 V6 engine)	29
		AUTOMATIC TRANSMISSION	16	SERVICE SCHEDULE (2.0 T4 MAir engine)	31
		GEAR LEVER	16		

SERVICE SCHEDULE (2.2 JTD engine).....	33
REFILLING	35
WHEELS.....	37
COLD TYRE INFLATION PRESSURES (psi/bar).....	37
CONNECT	37
CONTROLS ON TUNNEL.....	37
WIDGETS.....	38
RADIO (TUNER) MODE	38
MEDIA MODE	38
PHONE MODE	39
NAVIGATION MODE.....	39
SETTINGS	39
PERFORMANCE	40
CAR INFORMATION	40
ALFA CONNECT SERVICES	40
OFFICIAL TYPE APPROVALS	40
RADIO EQUIPMENT.....	40
RADIO FREQUENCY DEVICES	40

SUPPLEMENTS

EURO 6B.....



AUSTRALIA



DASHBOARD



1 9490460

- (1) External light switch
- (2) Left stalk (external lights/LDW (Lane Departure Warning) system/LKA (Lane Keeping Assist) system)
- (3) Instrument panel features
- (4) Right stalk (Windscreen wiper)
- (5) Right-side steering wheel controls (interaction with Connect system)
- (6) Ignition device (START/STOP ENGINE)
- (7) Left-side steering wheel controls (Speed Limiter/ Cruise Control/ Active Cruise Control/ HAS (Highway Assist) system/TJA (Traffic Jam Assist) system)

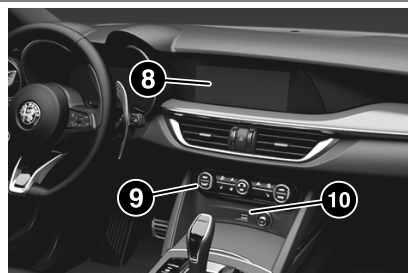

2 9490461

- (8) Connect system
- (9) Automatic dual-zone climate control system
- (10) 12V Power socket/USB port

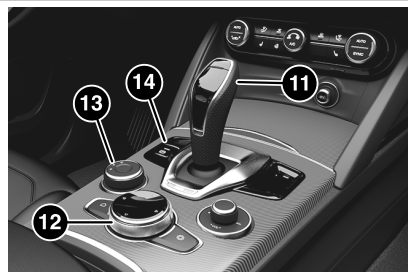

3 9490462



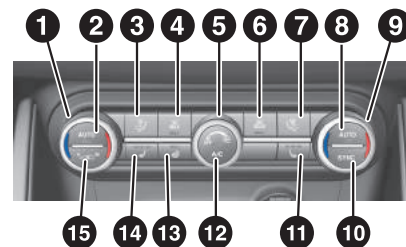

- (11) Gear lever
- (12) Rotary Pad/ Connect system interaction controls
- (13) Alfa DNA™ system selector
- (14) Electric Parking Brake (EPB)

AUTOMATIC DUAL-ZONE CLIMATE CONTROL SYSTEM



4 04156V0770EM

- (1) Left-side temperature
- (2) **AUTO** Automatic operation (left side)
- (3) Left-side air distribution
- (4) MAX-DEF function (rapid defrosting/demisting)
- (5) Fan speed
- (6) Heated rear window
- (7) Right-side air distribution
- (8) **AUTO** Automatic operation (right side)
- (9) Right-side temperature
- (10) **SYNC** alignment of set temperatures (left-side/right-side)
- (11) Right heated seat (where provided)
- (12) **A/C** Climate control compressor on

- (13)  Heated steering wheel (where provided)
- (14)  Left heated seat (where provided)
- (15)  ^A  ^M Internal air recirculation/automatic function selection

TAILGATE

OPENING THE TAILGATE FROM INSIDE

With the tailgate unlocked, lift the button (1) fig. 5 to open it from inside the car.



5 04206V0002EM

CLOSING THE TAILGATE FROM OUTSIDE

The buttons on the tailgate interior trim operate:

- (2) fig. 6: button to close the tailgate;
- (3) fig. 6: button to close the tailgate and lock all the doors, including the tailgate.

To stop the tailgate moving, press either of the two close buttons.



6 04056V0055EM

AUTOMATICALLY OPENING/CLOSING THE ELECTRICALLY OPERATED TAILGATE IN "HANDS-FREE" MODE (where provided)

To make the tailgate move, go behind the centre of the car, about 50 cm away from the tailgate, and make a kicking movement with your foot under the bumper, fig. 7.



7 04206V0015EM

DISPLAY

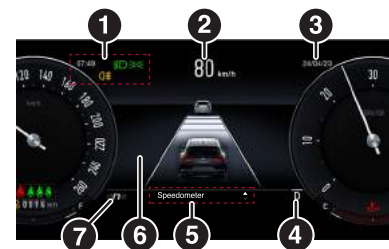

8 9490237

The following information can be shown on the instrument panel display, fig. 8:

- (1) Customisable notification area, main beam/dipped beam, side lights, rear fog lights icons, second instantaneous speed display ("Evolved" display only).

(2) Instantaneous speed (numerical), driving assistance system notification icons

(3) Customisable notification area, engine torque/External temperature display

(4) Gear shift indicator (GSI)/Automatic transmission information

(5) Menu title, screen navigation indications (e.g.: reset counters, customisation of information display, etc.)

(6) Main screen with driving assistance system notifications/Car speed display

(7) Operating mode display: Dynamic, Natural, Advanced Efficiency, Race (where provided)

INSTRUMENT PANEL

"HERITAGE" DISPLAY



9

9550238



10

9550239

"EVOLVED" DISPLAY



11

9550412

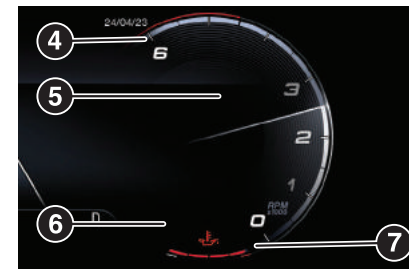

12

9550413

"RELAX" DISPLAY



13

9550414



14

9550415

"Race" DISPLAY (Quadrifoglio versions)

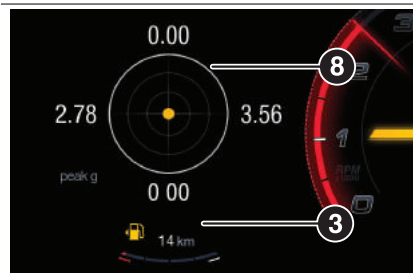

15

9550416

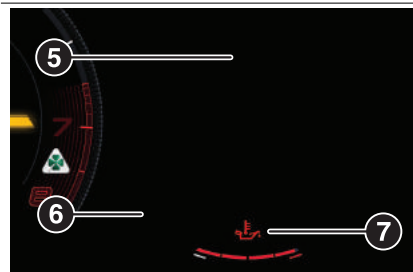

16

9550417

Information shown:

- (1) Speedometer (excluding "Relax" display)
- (2) Driving assistance system indications/ Customisable notification area ("Relax" display only)/ Instantaneous speed display ("Relax" display only)
- (3) Digital fuel level gauge, SBA (Seat Belt Alert) system indications, TPMS (Tyre Pressure Monitoring System) notification icon
- (4) Tachometer
- (5) Customisable and notification area with pop-ups
- (6) Notification icon display area
- (7) Digital engine oil temperature indicator
- (8) Longitudinal/lateral acceleration trend display, considering gravity acceleration as a reference unit. Lateral acceleration peaks are also displayed ("Race" display only)

WARNING LIGHTS AND MESSAGES

WARNING The instrument panel warning lights/symbols are accompanied by a dedicated message and/or acoustic warning where applicable. These indications are indicative and precautionary and as such must not be considered as exhaustive and/or alternative to the information contained in the online Owner Handbook, which you are advised to read carefully in all cases. Always refer to the information in this section in the event of a failure indication.

WARNING Causes of ignition and actions to be taken are illustrated in detail in the online Owner Handbook. However, the following actions are briefly outlined in this Quick Guide:











(*) Contact an Alfa Romeo Dealership











(**) Repair immediately using the dedicated "Tirekit" kit and contact an Alfa Romeo Dealership

INSTRUMENT PANEL DISPLAY FAILURE

All warning lights remain off in the event of an instrument panel display failure. In this case, contact an Alfa Romeo Dealership.

RED WARNING LIGHTS/SYMBOLS

Warning Light/Symbol	Meaning
	AIRBAG FAILURE (*)
	INSUFFICIENT BRAKE FLUID (*)/ELECTRIC PARKING BRAKE ON
	EBD FAILURE (*)
	
	POWER STEERING FAILURE
	ALFA™ SYSTEM STEERING TORQUE (AST) FAILURE
	SEAT BELTS REMINDER
	ALTERNATOR FAILURE (*)
	DOORS OPEN
	COOLANT TEMPERATURE TOO HIGH (*)

Warning Light/Symbol	Meaning
	BONNET NOT PROPERLY SHUT
	LUGGAGE COMPARTMENT NOT PROPERLY SHUT
	LOW ENGINE OIL PRESSURE (*)
	LOW ENGINE OIL LEVEL/OIL OVER MAXIMUM LEVEL (*)
	ENGINE OIL TEMPERATURE TOO HIGH (*)
	AUTOMATIC TRANSMISSION FAILURE (*)
	BRAKE DISC TEMPERATURE
	DAA SYSTEM ACTIVATION
	SPEED LIMIT EXCEEDED
	BRAKE DISC TEMPERATURE

AMBER WARNING LIGHTS/SYMBOLS

Warning Light/Symbol	Meaning
	ABS FAILURE (*)

Warning Light/Symbol	Meaning
	ELECTRIC PARKING BRAKE FAILURE (*)
ESC	ESC SYSTEM INTERVENTION/ ESC SYSTEM FAILURE (*)/ HILL START ASSIST SYSTEM FAILURE (*)
ESC OFF	PARTIAL/TOTAL DEACTIVATION OF ACTIVE SAFETY SYSTEMS
	EOBD/ INJECTION SYSTEM FAILURE (*)/ DAMAGED CATALYTIC CONVERTER
	AdBlue® (UREA) INJECTION SYSTEM FAILURE (Diesel versions) (*)
	TPMS SYSTEM FAILURE (**)/ TYRE PRESSURE LOW
	REAR FOG LIGHT
	GLOW PLUG PREHEATING/ GLOW PLUG PREHEATING FAILURE (*)
	FUEL CUT-OFF SYSTEM OPERATION

Warning Light/Symbol	Meaning
	LANE DEPARTURE WARNING (*)/ LANE KEEPING ASSIST FAILURE (*)
	FUEL RESERVE/LIMITED RANGE
	LOW WINDSCREEN WASHER LEVEL
	WINDSCREEN WIPER FAILURE (*)
	ACTIVE CRUISE CONTROL SYSTEM FAILURE (*)
	PARK SENSORS SYSTEM FAILURE (*)
	FORWARD COLLISION WARNING (FCW) SYSTEM FAILURE (*)
	START&STOP/EVO SYSTEM FAILURE (*)
	TOW HOOK FAILURE (*)
	SPEED LIMITER FAILURE (*)
	DPF CLEANING IN PROGRESS/ GPF CLEANING IN PROGRESS/ GPF FAILURE (*)

Warning Light/Symbol	Meaning
	FORWARD COLLISION WARNING (FCW) SYSTEM OFF
	BLIND SPOT MONITORING SYSTEM FAILURE
	ENGINE IMMOBILIZER SYSTEM FAILURE (*)/ BREAK- IN ATTEMPT/ ALARM FAILURE (*)
	AdBlue® (UREA) LEVEL LOW
	WATER IN DIESEL FILTER (*)
	RAIN SENSOR FAILURE (*)
	BRAKE PAD WEAR (*)
	CARBO-CERAMIC BRAKE (CCB) DISC WEAR (*)
	KEYLESS START SYSTEM FAILURE (*)
	POSSIBLE ICE ON ROAD
	ENGINE OIL DEGRADED (*)





Warning Light/Symbol	Meaning
	FUEL CUT-OFF SYSTEM FAILURE (*)
	EXTERNAL LIGHT FAILURE (*)
	AUTOMATIC MAIN BEAM HEADLIGHTS FAILURE (AHB) (*)
	DUSK SENSOR FAILURE (*)
	FUEL LEVEL SENSOR FAILURE (*)
	ENGINE OIL LEVEL SENSOR FAILURE (*)
	GENERIC FAILURE (*)
	ABS ACTIVATION
	DYNAMIC TRACTION CONTROL SYSTEM FAILURE (*)
	ALL-WHEEL DRIVE FAILURE (*)
	TEMPORARY ALL-WHEEL DRIVE FAILURE (*)

Warning Light/Symbol	Meaning
	DAA SYSTEM FAILURE (*)
	HAS SYSTEM (*)/TJA SYSTEM FAILURE (*)
	SHOCK ABSORBERS (ADC) FAILURE (*)
	SOFT SUSPENSION CALIBRATION
	SUSPENSION CALIBRATION CHANGE
	TRANSMISSION FLUID OVERHEATING (*)
	ENGINE OIL PRESSURE SENSOR FAILURE (*)
	TRAILER LIGHT CONTROL MODULE FAILURE (*)
	FUEL TANK CAP NOT CLOSED
	AFS SYSTEM FAILURE (*)
	DIPPED BEAM AUTOMATIC ADJUSTMENT FAILURE



Warning Light/Symbol	Meaning
	TAILGATE ELECTRIC OPENING/CLOSING FAILURE
	ELECTRIC TOW HOOK FAILURE

GREEN WARNING LIGHTS/SYMBOLS





Warning Light/Symbol	Meaning
	SIDE LIGHTS AND DIPPED BEAM HEADLIGHTS
	FOG LIGHTS
	DIRECTION INDICATORS
	START&STOP EVO SYSTEM OPERATION
	AUTOMATIC DIPPED BEAM HEADLIGHTS

Warning Light/Symbol	Meaning
	DIPPED BEAM HEADLIGHTS
	CRUISE CONTROL ACTIVATION
	ACTIVE CRUISE CONTROL (ACC) ACTIVATION
	SPEED LIMITER ACTIVATION
	HILL DESCENT CONTROL (HDC SYSTEM)





BLUE WARNING LIGHTS/SYMBOLS

Warning Light/Symbol	Meaning
	MAIN BEAM HEADLIGHTS ACTIVE
	AUTOMATIC MAIN BEAM HEADLIGHTS ACTIVE

WHITE WARNING LIGHTS/SYMBOLS

Warning Light/Symbol	Meaning
	AUTOMATIC DIPPED BEAM HEADLIGHTS LIT
	AUTOMATIC DIM HIGH BEAMS LIT
	GEAR SHIFT INDICATOR (SINGLE GEAR SHIFT SUGGESTION)
	GEAR SHIFT INDICATOR (DOUBLE GEAR SHIFT SUGGESTION)

LANE KEEPING ASSIST SYMBOLS

Symbol on the display	Meaning
	SENSOR NOT AVAILABLE
	SYSTEM ON
	SYSTEM ON (only one side line detected)
	CAR CLOSE TO SIDE LINE
	CROSSING SIDE LINE

THE KEYS



ELECTRONIC KEY



ATTENTION

1) Do not swallow the battery. Danger of chemical burns. The keys contain a small battery. If the battery is swallowed, it can cause severe internal burns in just 2 hours and cause death. Keep new and used batteries out of the reach of children. If the battery compartment does not close securely, discontinue use of the product and keep it out of reach of children. If you believe that batteries may have been swallowed or inserted inside the body, seek medical attention immediately. The emergency key (where provided) must be immediately inserted into the electronic key to prevent easy access to the battery.

IGNITION DEVICE

⚠ 2) 3) 4)



17

04026V0001EM

- STOP:** engine off, steering column locked.
- ON** (single button press): all electrical devices are available.
- AVV:** engine starting.



ATTENTION

2) Always take the key with you when you leave your car to prevent someone from accidentally operating the controls. Remember to engage the electric parking brake. Never leave children unattended in the car.

3) Before leaving the car, ALWAYS engage the electric parking brake. Activate mode P (Park) and press the ignition device to set it to STOP. When leaving the car, always lock all the doors by pressing the button on the handle.

4) For versions equipped with the Keyless Start system, do not leave the electronic key inside or near the car or in a place accessible to children. Do not leave the car with the ignition device in ON position. A child could activate the electric window winders, other controls or even start the car.

EXTERNAL LIGHTS

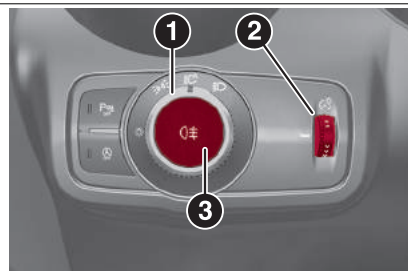

18

9490200

DIPPED BEAM HEADLIGHTS

Turn the light switch (1) fig. 18 to  to switch on the side lights, the lights on the instrument panel and the dipped beam headlights.

The  warning light switches on in the instrument panel.

DAYTIME RUNNING LIGHTS (DRL) AND SIDE LIGHTS (Daytime Running Lights) (where provided)



⚠ 5) 6)

With the ignition device in the ON position and the light switch (1) fig. 18 turned to the  position, the daytime running lights, the rear light clusters and the number plate lights turn on automatically.

REAR FOG LIGHT



Press the button (2) fig. 18 to switch the light on.

PARKING LIGHTS

They are turned on if the light switch (1) fig. 18 is turned first to the  position and then to the  position within a few seconds from stopping the engine.

The  warning light on the instrument panel turns on.

MAIN BEAM HEADLIGHTS

To activate the fixed main beam headlights push the left lever towards the instrument panel fig. 19. The light switch must be turned to the  or  position.

With main beam headlights on, the warning light/icon  on the instrument panel will come on.

The main beam headlights are switched by pushing the left stalk forward again.

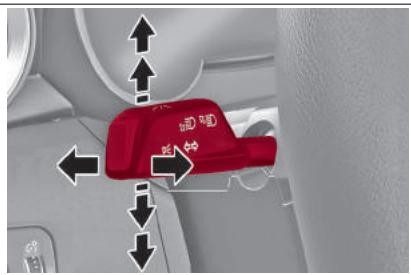





19

9550234

DIRECTION INDICATORS

Move the left stalk fig. 19 to the end of its travel (unstable position):

-  *upwards*: activates the right direction indicator;
-  *downwards*: activates the left direction indicator.

Warning light  or  will blink on the instrument panel

"Lane Change" function

When you want to signal the change of the driving lane, move the lever until the first impulse (about half stroke).

The direction indicator on the side selected will be activated for 3 flashes and then go out automatically.

AUTO FUNCTION (Dusk sensor)

This function switches the headlights on/off automatically according to the environmental light.

With the ignition device in the ON position, turn the light switch (1) fig. 18 to the  position.



ATTENTION

5) *The daytime running lights are an alternative to the dipped headlights for driving during the daytime in countries where it is compulsory to have lights on during the day; where it is not compulsory, the use of daytime running lights is permitted.*

6) *Daytime running lights cannot replace dipped beam headlights when driving at night or through tunnels. The use of daytime running lights is governed by the highway code of the country in which you are driving. Comply with legal requirements.*

TPMS (Tyre Pressure Monitoring System)

(where provided)

 7) 8) 9) 10) 11)

 1)

The TPMS signals the driver a possible insufficient pressure if this falls below the warning limit for any reason, including the effects of low temperature and normal loss of pressure from the tyre.

The TPMS will stop indicating insufficient tyre pressure when it is equal to or greater than the prescribed cold inflation pressure.

If insufficient tyre pressure is indicated () symbol shown on the instrument panel), increase the inflation pressure up to the prescribed cold inflation value.

Once the system receives the updated inflation pressures, it will automatically update and the () symbol will turn off. The vehicle might need to be driven at a speed higher than about 15 mph (25 km/h) up to 20 minutes for the TPMS to receive this information.

To view TPMS information on the Connect system display, and activate the "Car information" function, fig. 20 using the corresponding widget in the Main Menu.

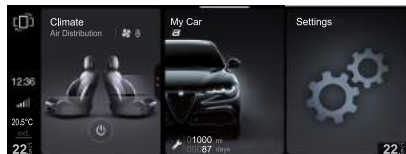

20

12126V2305EM

If the inflation pressure corresponds to the correct value, "OK" will appear on the display, otherwise "KO" will appear.

Press the graphic button (1) fig. 21 on the display of the Connect system to see the screen showing the inflation pressures of each tyre.



21

12126V2310EM



ATTENTION

7) The presence of the TPMS does not permit the driver to neglect regular checks of the tyre pressure, including for the spare tyre, and correct maintenance: the system is not used to signalling a possible tyre fault.

8) Tyre pressure must be checked with tyres rested and cold. Should it become necessary for whatever reason to check pressure with warm tyres, do not reduce pressure even though it is higher than the prescribed value. Repeat the check when the tyres are cold.

9) Should one or more wheels be fitted without sensors, the system will no longer be available and a warning message will be shown on the display, until wheels with sensors are fitted again.

10) The TPMS cannot indicate sudden tyre pressure drops (e.g. if a tyre bursts). In this case, stop the car, braking with caution and avoiding abrupt steering.

11) Changes in external temperature may cause tyre pressures to vary. The system may temporarily indicate insufficient pressure. In this case, check the tyre pressure when cold and, if necessary, restore the inflation values.



WARNING

1) The Tyre Repair Kit, provided with the car, is compatible with the TPMS sensors. Using sealants different from that in the original kit may compromise its operation. If sealants not equivalent with the original one are used, it is recommended to have the TPMS sensor operation checked by a qualified repair centre.

AUTOMATIC TRANSMISSION

⚠ 12) 13) 14) 15)

GEAR LEVER

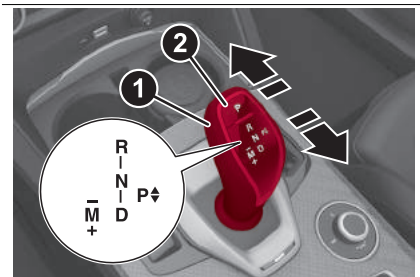

22

07076V0686EM

- P** = Park
- R** = Reverse
- N** = Neutral
- D** = Drive (automatic forward speed)
- AutoStick:**
 - + shifting up in sequential driving mode
 - – shift down in sequential driving mode

LEVERS ON THE STEERING WHEEL

(where provided)

Left shift paddle (-): pull the left shift paddle towards the steering wheel and release it to shift down.

Right shift paddle (+): pull the right shift paddle towards the steering wheel and release it to shift up.

To engage N (Neutral), pull both levers simultaneously.

To activate D (Drive) mode, from N (Neutral), P (Parking) and R (Reverse) position: push the brake pedal and the right paddle (+).

Deactivation: To deactivate the sequential driving bring the gear lever back in position D (Drive) ("automatic" mode).



23

9550205



ATTENTION

12) Never use position P (Park) instead of the electric parking brake. Always engage the electric parking brake when parking the car to avoid the accidental movement of the car.

13) If the P (Park) position is not engaged, the car could move and injure people. Before leaving the car, make sure that the gear lever is in position P and that the electric parking brake is engaged.

14) Do not shift the gear lever to N (Neutral) and do not stop the engine when driving on a downhill road. This type of driving is dangerous and reduces the possibility of intervening in the case of variation of the road traffic or surface. You risk losing control of your vehicle and causing accidents.

15) NEVER leave children unattended inside the car, let alone leave the car with the doors unlocked in a place that children can access easily. Children may seriously, or even fatally, injure themselves. Also ensure that children do not inadvertently operate the electric parking brake, the brake pedal or the gear lever.

"ALFA DNA™" SYSTEM



24

04026V0997EM

By using the selector fig. 24 on the central tunnel, different response modes to be selected according to driving style and road conditions.

- d = Dynamic** (sports driving mode)
- n = Natural** (mode for driving in normal conditions)
- a = Advanced Efficiency** (driving mode for maximum fuel savings)
- RACE** (where provided) = track race driving mode
-  (where provided) = changes the suspension setting

MANUAL SOS CALL

(for versions/markets where provided)

This is designed to provide support in the event of an accident and/or emergency (SOS) the function is activated:

- automatically in the event of a major collision recorded by the device aboard the car;
- manually, by pressing the SOS button located on the ceiling light fig. 25 or by means of the appropriate menu fig. 26 on the Connect system (for versions/markets, where provided).

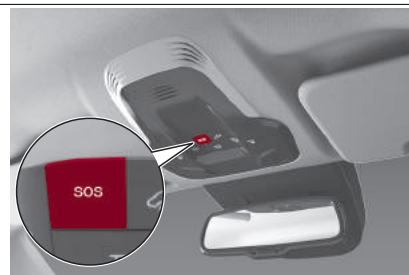

25

04136S0073EM

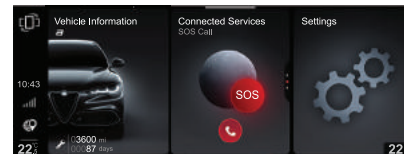

26

12126V2330EM

WARNING If the SOS emergency service is activated, the call will be routed automatically to a private call centre. We hereby specify that, whenever the SOS call is referred to the text, the SOS call is to be considered managed by private service providers. This SOS call service is not the e-call system.

If the system is unable to establish the voice call, or the line disconnects due to insufficient coverage, the SOS service will try to call the operational centre again for 5 minutes.

Privacy: GPS location is always active for SOS. Deactivating it via the menu items in the "Settings" menu of the Connect system will make some with other services unavailable (see the "Settings" chapter of the Connect system for more details).

WARNING The icon is shown at the bottom left of the Connect system display when the geolocation function is active (ON). When geolocation is on, the vehicle position is tracked to enable the functions that require it. When geolocation is off, the vehicle position is only tracked by the navigation, safety, insurance and driver assistance systems (where provided). See the Connect system "Settings" chapter to deactivate the function.

WARNING Malfunctions of the SOS call system are indicated when the engine is started, when the malfunction is detected and by a corresponding message on the Connect system display. Contact an Alfa Romeo Dealership as soon as possible.

WARNING Ignoring malfunction warnings displayed by the Connect system for a long time could lead to being unable to make an SOS call when needed.

CHILD RESTRAINT SYSTEMS

For optimal protection in the event of an impact, all occupants must be seated and wearing adequate restraint systems, including newborn and other children! This prescription is compulsory in all EC countries according to EC Directive 2003/20/EC.

PASSENGER'S FRONT AIRBAG AND CHILD RESTRAINT SYSTEMS

 16) 17) 18) 19) 20) 21) 22) 23) 24) 25) 26)

Rearward-facing child restraint systems must **NEVER** be fitted on the front seat since in the event of a collision the airbag activation may cause fatal injuries to the transported child.

ALWAYS comply with the instructions on the label stuck on the passenger side sun visor (A) or (B) fig. 27.

A



B



27

9490193



28

0610650376EM

DEACTIVATING/ACTIVATING THE PASSENGER SIDE AIRBAGS: FRONT AIR BAG AND SIDE BAG (where provided)

The ON and OFF status LEDs are on the front ceiling light, fig. 28.

The LEDs indicates the passenger airbag protection status:

- ❑ **Passenger protection activated:** the ON LED switches on fixed
- ❑ **Passenger protection deactivated:** the OFF LED turns on fixed



ATTENTION

16) *Incorrect fitting of the child restraint system may result in an inefficient protection system. In the event of an accident the child restraint system may become loose and the child may be injured, even fatally. When fitting a restraint system for newborns or children, strictly comply with the instructions provided by the Manufacturer.*

17) *When the child restraint system is not used, secure it with the seat belt or with the ISOFIX anchorages, or remove it from the car. Do not leave it unsecured inside the passenger compartment. In this way, in the event of sudden braking or an accident, it will not cause injuries to the occupants.*

18) *After installing a child restraint system, do not move the seat: always remove the child restraint system before making any adjustment.*

19) *Always make sure that the belt strap does not pass under the child's arms or behind its back. In the event of an accident the seat belt will not be able to secure the child, with the risk of injury, including fatal injury. Therefore the child must always wear the seat belt correctly.*

20) *Do not use the same lower anchoring to install more than one child restraint system.*

21) *If a Universal ISOFIX child restraint system is not fixed to all three anchorages, it will not be able to protect the child correctly. In the event of an accident, the child could be seriously or fatally injured.*

22) *Fit the child restraint system when the car is stationary. The child restraint system is correctly secured to the brackets when you hear the click. Follow the instructions for assembly, disassembly and positioning that the Manufacturer must supply with the child restraint system.*

23) **SEVERE DANGER** *When a front passenger airbag is fitted, do not install rearward facing child restraint systems on the front passenger seat.*

Deployment of the airbag in a crash could cause fatal injuries to the child regardless of the severity of the collision. It is advisable to always carry children in a child restraint system on the rear seat, which is the most protected position in the event of a collision.

24) *On the sun visor there is a label with suitable symbols reminding the user that it is compulsory to deactivate the airbag if a rearward facing child restraint system is fitted. Always follow the instructions on the passenger-side sun visor.*

25) *Should it be necessary to carry a child on the passenger side front seat in a rear facing child restraint system, the passenger side front and side airbags must be deactivated through the main menu of the Connect system, verifying deactivation by checking that the  OFF LED on the front ceiling light is lit. Move the passenger's seat as far back as possible to avoid contact between the child seat and the dashboard.*

26) *Do not move the front or rear seat if a child is seated on it or on the dedicated child restraint system.*

REPLACING A BULB



2)



WARNING

2) The number plate lights are of the LED-type. For bulb replacement, contact an Alfa Romeo Dealership.

DRIVING TIPS

In daily use, the consumption of an electric car may depend on the following factors, which can have a considerable impact:

- car maintenance;
- tyre pressure;
- unnecessary loads;
- roof rack/ski rack;
- electric devices;
- climate control system use;
- devices for aerodynamic control.

CHANGING A WHEEL

(for versions/markets where provided)

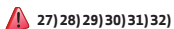

27) 28) 29) 30) 31) 32)



3) 4)

Proceed as follows:

- stop the car in a position that is not dangerous for oncoming traffic where you can change the wheel safely. The car must be stopped in a lay-by, car-park or parking or service area, and the ground must be as level as possible and sufficiently compact;
- stop the engine, switch on the hazard warning lights, and engage the electric parking brake and P (Park) mode;
- make sure that any passengers get out of the car and go to a safe place where they will not obstruct traffic or be exposed to the risk of injury. In the event of a puncture, change the tyre in accordance with the laws of the country in which you are travelling. Wear the reflective safety jacket (compulsory by law) before getting out of the car;

when the situation dictates it (for your own safety and to comply with the regulations in force in the country where you are), take the warning triangle and position it at a suitable distance from the car;

- open the boot and lift the mat;
- unscrew the locking device (1) fig. 29, and take out the space-saver wheel and inflation compressor;
- take the wrench provided, loosen the fixing bolts by about one turn and remove the damaged wheel. Shake the car to help detach the rim from the wheel hub;

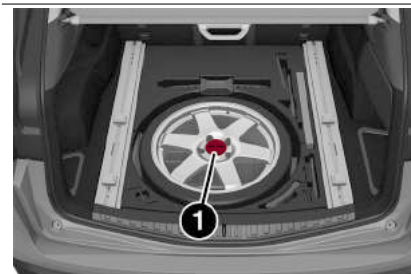

29

08066V0010EM

position the jack (4) fig. 30 under the car, near the wheel to be changed, taking care not to damage the plastic aerodynamic guard;

- ❑ lift the extension lever (2) fig. 30 on the wrench (3);
- ❑ turn the extension lever (2) fig. 30 clockwise until the round pin on the jack engages in the hole in the lifting block located about 15 cm from the outside edge of the body. The lifting points (5) are shown in fig. 30 and are marked by a triangle ▽ on the aerodynamic spoiler;
- ❑ alert any bystanders that the car is about to be raised, keep everyone away from the car and warn them that nobody must touch it until it has been lowered;
- ❑ turn the extension lever (2) fig. 30 until the wheel is a few centimetres off the ground;
- ❑ remove the five wheel fastening bolts and take the wheel off;
- ❑ make sure the contact surfaces between space-saver wheel and hub are clean so that the fastening bolts will not come loose;
- ❑ fit the space-saver wheel by inserting the first bolt for two threads into the hole closest to the valve;
- ❑ take the wrench (3) fig. 30 and tighten the fixing bolts fully;

- ❑ inflate the space-saver wheel. To do this, remove the cap from the inflation valve on the space-saver wheel and screw on the compressor inflation hose fitting;

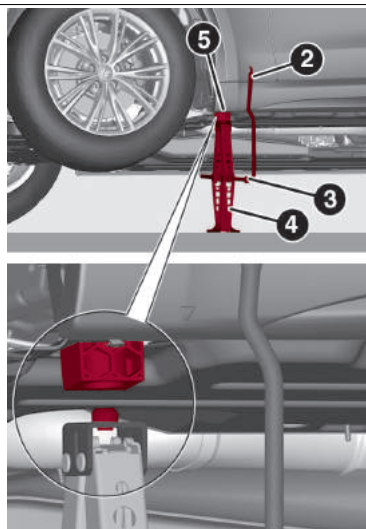

30

08066V0013EM

- ❑ make sure that the switch on the Tire Repair Kit compressor (see description on following pages) is in the **OFF** position, and insert the plug into the power socket in the boot or passenger compartment (under the climate control panel), then start the engine and put the switch on the Tire Repair Kit compressor in the **ON** position;
 - ❑ inflate the space-saver wheel to a pressure of 3 bar;
- WARNING** To safeguard the battery charge, it is advisable to leave the engine running throughout the inflation procedure, and check the inflation pressure of the space-saver wheel on the pressure gauge of the Tire Repair Kit with the compressor off to obtain a more accurate reading.



ATTENTION

27) The jack is a tool developed and designed only for changing a wheel, if a tyre gets punctured or damaged, on the vehicle with which it is supplied or on other vehicles of the same model. Any other use, e.g. to jack up other vehicle models or different things, is strictly prohibited. Never use for maintenance or repair activities under the car or to exchange the summer/winter wheels and vice versa. Never go under the raised vehicle. Should it be necessary to work under the vehicle, contact an Alfa Romeo Dealership. Incorrect positioning of the jack may cause the raised vehicle to fall: use only in the positions indicated. Do not use the jack for loads higher than the one shown on its label. Never start the engine with vehicle raised. If the vehicle is raised more than necessary, everything can become more unstable, with the risk of the vehicle dropping violently. Thus, lift the vehicle only as needed in order to access the spare wheel.

28) The space-saver wheel must only be used in the event of an emergency. Never use it for more than strictly necessary and never exceed 80 km/h. There is an orange sticker on the space-saver wheel, which summarises the main warnings regarding wheel usage restrictions. Never remove or cover the label. The label contains the following indications in four languages: "Attention! For temporary use only! 80 km/h max.! Replace with standard wheel as soon as possible. Never cover this indication". Never apply a hubcap on a space-saver wheel. The car's driving characteristics will be modified with the space-saver wheel fitted. Avoid violent acceleration and braking, abrupt steering and fast cornering. Have the wheel repaired and refitted as soon as possible. Using two or more space-saver spare wheel at the same time is forbidden. Do not apply grease to the bolt threads before fitting: they could come unscrewed

29) Alert other drivers that the car is stationary in compliance with local regulations: hazard warning lights, warning triangle, etc. Any passengers on board should leave the car, especially if it is heavily laden. Passengers should stay away from on-coming traffic while the wheel is being changed. On hills or uneven roads, use chocks or appropriate objects to block the wheels of the car.

30) If left in the passenger compartment, the punctured wheel and jack constitute a serious risk to the safety of occupants in the event of accidents or sharp braking. Therefore, always place both the jack and punctured wheel in the dedicated housing in the boot.

31) It is extremely dangerous to attempt to change a wheel on the side of the car next to the driving lane: make sure that the car is at a sufficient distance from the road, to avoid being run over.

32) Never tamper with the inflation valve. Never introduce tools of any kind between the rim and the tyre. Check the tyre and space-saver wheel pressures regularly to ensure that they comply with the values given in the "Cold tyre inflation pressures" paragraph in the "Wheels" chapter.



WARNING

3) When turning the jack handle make sure that it can turn freely without scraping your hand against the ground. The moving components of the jack ("worm screw" and joints) can also cause injuries: avoid touching them. If you come into contact with lubricating grease, clean yourself thoroughly.

4) Contact an Alfa Romeo Dealership as soon as possible to have the correct tightening of the wheel bolts checked.

TYRE REPAIR KIT

(where provided)

 33) 34) 35) 36) 37) 38) 39) 40) 41) 42) 43) 44) 45)

 5) 6) 7)

 1)

The car may be equipped with a different Tire Repair Kit (OPT1 kit or OPT2 kit), depending on the version.

PRELIMINARY OPERATIONS

Proceed as follows:

- stop the car in a position that is not dangerous for oncoming traffic where you can change the wheel safely. The car must be stopped in a lay-by, car-park or parking or service area, and the ground must be as level as possible and sufficiently compact.
- stop the engine, turn on the hazard warning lights, engage the electric parking brake and set the gear lever to "P" (Park)
- steer the wheels completely
- if on a steep slope, place wedges or stones behind the wheels
- Put on the reflective safety jacket before getting out of the car (if required by the regulations in force). In any case, follow the road safety laws in force in the country where you are travelling

- make sure that any passengers get out of the car and go to a safe place where they will not obstruct traffic or be exposed to the risk of injury. In the event of a puncture, change the tyre in accordance with the laws of the country in which you are travelling

OPT1 KIT DESCRIPTION

The Tire Repair Kit consists of:

- a spray can (1) fig. 31 containing the sealant, equipped with filling hose (2);
- a compressor (4) complete with pressure gauge, connectors and adhesive label (3) with the wording "Max 80 km/50 mph" to be placed in a clearly visible position (e.g. on the dashboard) after repairing the tyre;
- some adaptors, for inflating different elements.

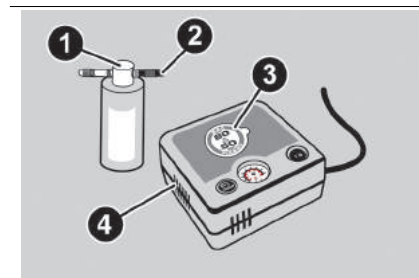

31

08066V0002EM

Inflation procedure

Proceed as follows:

- put on the gloves, connect the hose (5) fig. 32 to the spray can (1) using the fitting (6). Unscrew the tyre valve cap and screw the filler hose ring nut (2) onto the tyre valve;
- make sure that the switch (7) fig. 33 on the compressor (4) is in the "0" (off) position;
- insert the plug into the socket in the boot and next start start the engine;

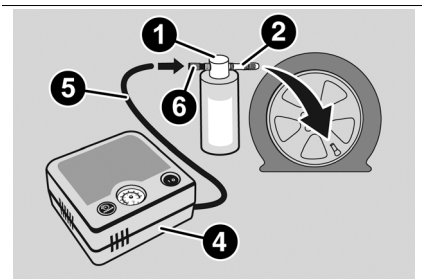

32

08066V0004EM

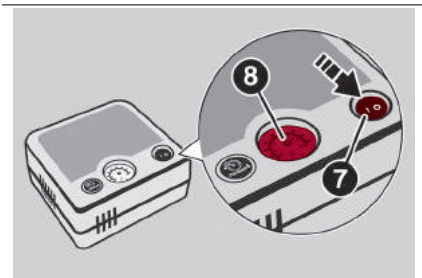

33

08066V0005EM

- ❑ start the compressor by putting the switch (7) fig. 33 in the "I"(on) position;
- ❑ inflate the tyre to a pressure of at least 32 psi (2.2 bar). In order to obtain a more precise reading, check the pressure value on pressure gauge (8) fig. 33 with the compressor off;

❑ if a pressure of at least 26 psi (1.8 bar) is not reached within 15 minutes, the tyre is too damaged to be repaired; do not resume driving, but contact an Alfa Romeo Dealership;

❑ after having driven for about 8 km/ 5 miles, stop, engage the electric parking brake and recheck the tyre pressure;

❑ if the measured pressure is unchanged 32 psi (2.2 bar), continue driving to an Alfa Romeo Dealership;

❑ if the measured pressure is between 19 psi and 30.5 psi (1.3 and 2.1 bar), restore pressure to 32 psi (2.2 bar), continue driving to an Alfa Romeo Dealership;

❑ if the measured pressure is lower than 19 psi (1.3 bar), the tyre is too damaged to be repaired. Do not continue driving, but contact an Alfa Romeo Dealership.

WARNING Only use original tyre repair spary cans, which can be purchased at an Alfa Romeo Dealership.

WARNING To conserve the battery charge, it is advisable to leave the engine running throughout the inflation process.

OPT2 KIT DESCRIPTION

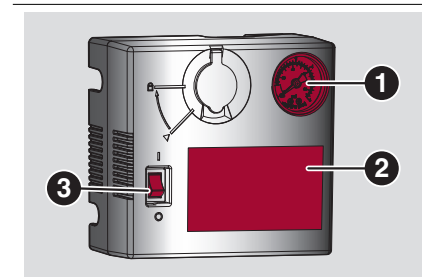

34

9550445

- (1) fig. 34 Pressure gauge
- (2) Instruction label
- (3) ON/OFF switch

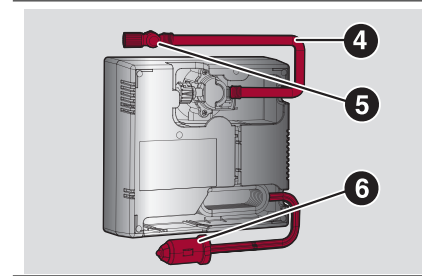

35

9550446

- (4) fig. 35 Air tube
- (5) Deflation button
- (6) 12V power supply cable/ plug

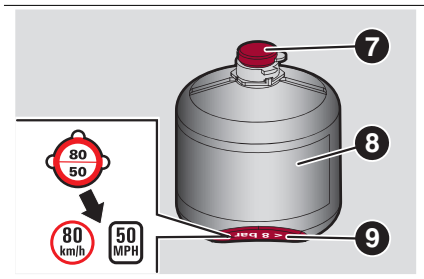

36

9550447

- (7) fig. 36 Cap for the sealant bottle
- (8) Sealant bottle and expiry date
- (9) Speed label

Description

The kit is composed of a compressor (1), fig. 37, a cartridge (2) containing the sealant and an adhesive label (3) with the wording "Max 80 km/ 50 mph", to be applied in a visible position (e.g. dashboard) after repairing the tyre.

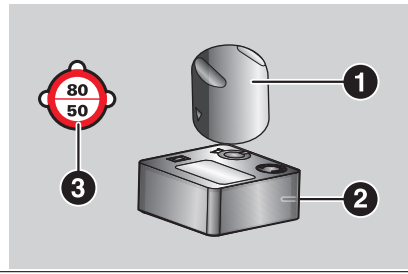

37

9550448

Repair procedure

Proceed as follows:

- take the kit, detach the speed limit sticker and apply it in a clearly visible position, e.g. on the steering wheel;
- open the cap on the compressor, engage the cartridge and turn it one quarter turn clockwise, fig. 38;
- remove the cap from the tyre valve and screw the black compressor tube onto the valve;
- make sure that the ON-OFF switch is in the off position (switch in the 0 position);

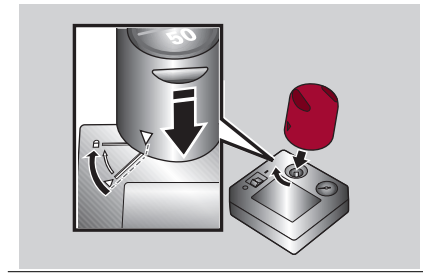

38

9550450

- plug the electrical connector into the 12V socket in the car, fig. 39, and then start the engine;
- ensure that the ON/OFF switch is in the "0" (off) position;
- plug the electrical connector, fig. 39, into the 12V socket in the car and then start the engine;

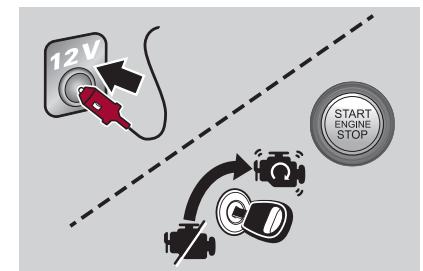

39

9550451

- move the ON/OFF switch fig. 40 to the "I" (on) position to start the compressor;

□ when the pressure gauge displays the prescribed pressure specified in the “Wheels” chapter in this publication, in the “Technical specifications” section of the “Wheels” chapter of the online Owner Handbook or on the specific label, turn off the compressor by moving the button to the OFF position (O)

If the pressure gauge indicates a pressure lower than 2.0 bar/ 29 psi within 10 minutes of starting the compressor, turn off the compressor, disconnect the black compressor tube from the tyre valve, unscrew the cartridge from the compressor by turning it a quarter turn anticlockwise and lift it out. Move the car by approximately 10 metres to allow the distribution of the sealant.

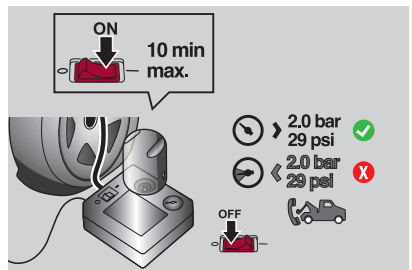

40

9550452

Stop safely, switch on the hazard warning lights, set the gear lever to P, leave the wheels fully steered and then stop the engine. If on a steep slope, place a wedges or stones behind the wheels and restore the prescribed pressure using the black compressor tube.

If also in this case the pressure is lower than 2.0 bar/ 29 psi 10 minutes after turning on, do not resume driving and contact an Alfa Romeo Dealership.

After driving for about 8 km/ 5 miles, fig. 41, stop safely, switch on the hazard warning lights, set the gear lever to P, leave the wheels fully steered and then stop the engine. When parked on a steep slope, place a wedge or stone behind the wheels.

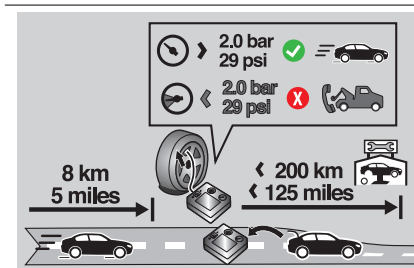

41

9550454

Take the compressor and restore the pressure using the black inflation tube. If the pressure shown is higher than 2.0 bar/ 29 psi, restore the pressure and drive safely to an Alfa Romeo Dealership as soon as possible. If the pressure is lower than 2.0 bar/ 29 psi, do not resume driving but contact an Alfa Romeo Dealership.

Pressure relief valve

If the tyre pressure is higher than expected, after switching off the compressor, it can be lowered by means of the button, fig. 42, located next to the black tube connection.

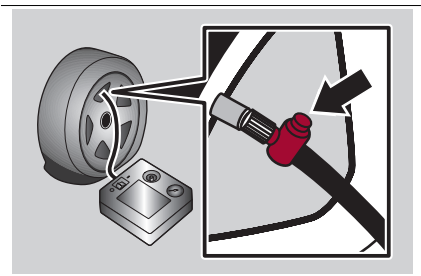

42

9550455

**ATTENTION**

33) **IMPORTANT:** Do not exceed 50 mph (80 km/h). Avoid sudden acceleration or braking. The Tyre Repair Kit provides a temporary repair, so the tyre must be examined and repaired by a specialist as soon as possible. Before using the Tyre Repair Kit, ensure that the tyre is not damaged excessively and that the rim is in good condition, otherwise do not use it and call roadside assistance. Do not remove foreign bodies from the tyre.

34) Punctures on the sides of the tyre may not be repaired. Do not use the Tyre Repair kit if the tyre was damaged as a result of being used when underinflated.

35) Wear the protective gloves provided with the Tyre Repair kit.

36) Apply the sticker where it can be easily seen by the driver as a reminder that the tyre has been treated with the Tyre Repair Kit. Drive carefully, particularly on bends.

37) Repairs are not possible in the case of damage to the wheel rim (bad groove distortion causing air loss). Do not remove foreign bodies (screws or nails) from the tyre.

38) As required by current regulations, the information on chemical substances for the protection of human health and the environment and on the safe use of the sealing fluid are on the packaging label. Compliance with the indications on the label is an essential condition to ensure the safety and the effectiveness of the product. Remember to carefully read the label before use; the user of the product is responsible for any damages caused by improper use. The sealing fluid has an expiry date. Replace the bottle if the sealant has expired.

39) Carefully read the cartridge label before use and avoid improper use. The kit should be used by adults and cannot be used by children.

40) The Tyre Repair Kit is not suitable for definitive repairs, so the repaired tyres may only be used temporarily. The Tirekit provides a temporary repair, therefore the tyre must be examined and repaired by a specialist as soon as possible.

41) Do not let the compressor turned on for more than 10 consecutive minutes - overheating hazard.

42) If the pressure falls below 26 psi (1.8 bar), do not drive any further: the Tyre Repair Kit cannot guarantee proper seal because the tyre is too damaged. Contact an Alfa Romeo Dealership.

43) You must always indicate that the tyre was repaired using the Tyre Repair Kit. Give the booklet to the technicians who will be handling the tyre that was treated using the Tyre Repair Kit.

44) Only use the Tyre Repair Kit when the tyre is punctured.

45) Indicate the presence of the stationary car in accordance with current regulations: hazard warning lights, warning triangle, etc. Those on board should get out of the vehicle and wait for the wheel to be repaired away from the threat posed by the traffic. On hills or uneven roads, use chocks or appropriate objects to block the wheels of the car.



WARNING

- 5) The hose surface may be hot.
- 6) The sealant liquid is effective for external temperatures between -40°F and +122°F (-40°C and +50°C). The sealing fluid has an expiry date and must be replaced periodically.
- 7) In the event of a puncture caused by foreign bodies, the kit may be used to repair tyres showing damage on the tyre tread up to max. 6 mm diameter.



WARNING

- 1) Dispose of the bottle and the sealant liquid properly. Have them disposed of in compliance with national and local regulations.

FUSES

 46) 47)

 8)



ATTENTION

46) Replacement of a fuse. Any service must be carried out exclusively by the Alfa Romeo Dealership or by a qualified repairer. The replacement of a fuse by a third party may cause a serious car fault.

47) Installation of electrical accessories. The vehicle's electrical circuit is designed to operate with standard or optional equipment, before installing other electrical equipment or accessories on the vehicle, contact the Alfa Romeo Dealership or a qualified repairer.



WARNING

- 8) FCA declines all responsibility for expenses arising from the repair of the vehicle or for anomalies resulting from the installation of accessories not supplied or not recommended by Alfa Romeo and not installed according to specifications, in particular when the combined consumption of all the additional equipment connected exceeds 10 mA.

SCHEDULED SERVICING

SERVICE SCHEDULE (2.9 V6 engine)

WARNING Once you have carried out the last intervention in the table, continue with the scheduled servicing, maintaining the frequency indicated in the plan by marking each operation with a dot or dedicated note. Attention: simply restarting the maintenance from the start of the plan may cause the allowed interval to be exceeded for some operations!

Thousands of miles	9	18	27	36	45	54	63	72	81	90
Thousands of kilometres	15	30	45	60	75	90	105	120	135	150
Years	1	2	3	4	5	6	7	8	9	10
Check battery state of charge with the proper instrument	•	•	•	•	•	•	•	•	•	•
Check tyre conditions/wear and adjust pressure, if necessary. Check Tire Repair Kit condition/expiry	•	•	•	•	•	•	•	•	•	•
Check operation of lighting system (headlights, direction indicators, hazard warning lights, boot, passenger compartment, glove compartment, instrument panel warning lights, etc.)	•	•	•	•	•	•	•	•	•	•
Check and, if necessary, top up fluid levels in engine compartment (engine oil, windscreen washer, etc.) (1)	•	•	•	•	•	•	•	•	•	•
Check the supply/engine management systems operation using the diagnosis equipment	•	•	•	•	•	•	•	•	•	•
Visually inspect condition of: exterior bodywork, underbody protection, pipes and hoses (exhaust, fuel system, brakes), rubber elements (gaiters, sleeves, bushes, etc.)		•		•		•		•		•
Check windscreen and rear window wiper blade position/wear	•		•		•		•		•	
Check operation of the windscreen wiper/washer system and adjust nozzles, if necessary	•		•		•		•		•	
Check cleanliness of hood and boot locks, cleanliness and lubrication of linkage		•		•		•		•		•
Visually inspect conditions and wear of front/rear disc brake pads and operation of pad wear indicators	•	•	•	•	•	•	•	•	•	•
Visually inspect the surface and edge of the carbon-ceramic brake discs (where provided)	•	•	•	•	•	•	•	•	•	•
Visually inspect the condition and tensioning of the accessory drive belt(s)	•	•	•		•	•	•		•	•
Replace brake pads/carbon-ceramic brake discs (where provided)										(5)

Thousands of miles	9	18	27	36	45	54	63	72	81	90
Thousands of kilometres	15	30	45	60	75	90	105	120	135	150
Years	1	2	3	4	5	6	7	8	9	10
Change engine oil and replace oil filter	●	●	●	●	●	●	●	●	●	●
Replace Transfer Case oil (for AWD versions)								●		
Spark plug replacement				●				●		
Replace accessory drive belt/s	(2)									
Replace air cleaner cartridge (3)		●		●		●		●		●
Change the brake fluid	(4)									
Replace passenger compartment filter (3)	○	●	○	●	○	●	○	●	○	●
Alfa Connect Box system battery replacement (where provided)	(6)									

- (1) Always only use the liquids shown in the handbook for topping up after having checked that the system is not damaged.
- (2) Areas that are not dusty: the maximum mileage is 60,000 km. The belt must be replaced every 4 years, regardless of distance travelled. If the car is used in heavy conditions (dusty areas, particularly harsh weather conditions, very low or very high temperatures for extended periods, urban driving, long periods of idling), the maximum mileage is 30,000 km. The belt must be replaced every 2 years regardless of the mileage.
- (3) If the vehicle is used in dusty areas, the cleaner should be replaced every 15,000 km.
- (4) Brake fluid is to be replaced every 2 years regardless of the distance travelled.
- (5) The actual interval for changing the brake pads and the carbon ceramic brake discs depends on the vehicle usage conditions and is signalled by the warning light or message on the instrument panel. Use the diagnosis equipment to reset the warning light every time the discs are replaced.
- (6) The battery in the Alfa Connect Box system must be replaced every 5 years, regardless of the mileage.
- Mandatory operations
- Recommended operations

SERVICE SCHEDULE (2.0 T4 MAir engine)

WARNING Once you have carried out the last intervention in the table, continue with the scheduled servicing, maintaining the frequency indicated in the plan by marking each operation with a dot or dedicated note. Attention: simply restarting the maintenance from the start of the plan may cause the allowed interval to be exceeded for some operations!

Thousands of miles	9	18	27	36	45	54	63	72	81	90
Thousands of kilometres	15	30	45	60	75	90	105	120	135	150
Years	1	2	3	4	5	6	7	8	9	10
Check battery state of charge with the proper instrument	•	•	•	•	•	•	•	•	•	•
Check tyre conditions/wear and adjust pressure, if necessary. Check Tire Repair Kit condition/expiry	•	•	•	•	•	•	•	•	•	•
Check operation of lighting system (headlights, direction indicators, hazard warning lights, boot, passenger compartment, glove compartment, instrument panel warning lights, etc.)	•	•	•	•	•	•	•	•	•	•
Check and, if necessary, top up fluid levels in engine compartment (engine oil, windscreen washer, etc.) (1)	•	•	•	•	•	•	•	•	•	•
Check the supply/engine management systems operation using the diagnosis equipment	•	•	•	•	•	•	•	•	•	•
Visually inspect condition of: exterior bodywork, underbody protection, pipes and hoses (exhaust, fuel system, brakes), rubber elements (gaiters, sleeves, bushes, etc.)		•		•		•		•		•
Check windscreen and rear window wiper blade position/wear	•		•		•		•		•	
Check operation of the windscreen wiper/washer system and adjust nozzles, if necessary	•		•		•		•		•	
Check cleanliness of hood and boot locks, cleanliness and lubrication of linkage		•		•		•		•		•
Visually inspect conditions and wear of front/rear disc brake pads and operation of pad wear indicators	•	•	•	•	•	•	•	•	•	•
Visually inspect the condition and tensioning of the accessory drive belt(s)	•	•	•		•	•	•		•	•
Change engine oil and replace oil filter	(2)									
Replace Transfer Case oil (for AWD versions)								•		
Spark plug replacement				•				•		
Replace accessory drive belt/s	(3)									

Thousands of miles	9	18	27	36	45	54	63	72	81	90
Thousands of kilometres	15	30	45	60	75	90	105	120	135	150
Years	1	2	3	4	5	6	7	8	9	10
Replace air cleaner cartridge (4)			●			●			●	
Change the brake fluid	(5)									
Replace passenger compartment filter (4)	○	●	○	●	○	●	○	●	○	●
Alfa Connect Box system battery replacement (where provided)	(6)									

- (1) Always only use the liquids shown in the handbook for topping up after having checked that the system is not damaged.
 - (2) The actual interval for changing engine oil and replacing the engine oil filter depends on the vehicle usage conditions and is signalled by the warning light or message in the instrument panel. In any cases, never exceed 1 year.
 - (3) Areas that are not dusty: the maximum mileage is 60,000 km. The belt must be replaced every 4 years, regardless of distance travelled. If the car is used in heavy conditions (dusty areas, particularly harsh weather conditions, very low or very high temperatures for extended periods, urban driving, long periods of idling), the maximum mileage is 30,000 km. The belt must be replaced every 2 years regardless of the mileage.
 - (4) If the vehicle is used in dusty areas, the cleaner should be replaced every 15,000 km.
 - (5) Brake fluid is to be replaced every 2 years regardless of the distance travelled.
 - (6) The battery in the Alfa Connect Box system must be replaced every 5 years, regardless of the mileage.
- Mandatory operations
 ○ Recommended operations

SERVICE SCHEDULE (2.2 JTD engine)

WARNING Once you have carried out the last intervention in the table, continue with the scheduled servicing, maintaining the frequency indicated in the plan by marking each operation with a dot or dedicated note. Attention: simply restarting the maintenance from the start of the plan may cause the allowed interval to be exceeded for some operations!

Thousands of miles	12	24	36	48	60	72	84	96	108	120
Thousands of kilometres	20	40	60	80	100	120	140	160	180	200
Years	1	2	3	4	5	6	7	8	9	10
Check battery state of charge with the proper instrument	•	•	•	•	•	•	•	•	•	•
Check tyre conditions/wear and adjust pressure, if necessary. Check Tire Repair Kit condition/expiry	•	•	•	•	•	•	•	•	•	•
Check operation of lighting system (headlights, direction indicators, hazard warning lights, boot, passenger compartment, glove compartment, instrument panel warning lights, etc.)	•	•	•	•	•	•	•	•	•	•
Check and, if necessary, top up the fluid levels in engine compartment (engine coolant, hydraulic clutch/brakes, windscreen washer, battery) (1)	•	•	•	•	•	•	•	•	•	•
Check the supply/engine control systems operation using the diagnostic socket	•	•	•	•	•	•	•	•	•	•
Visually inspect condition of: exterior bodywork, underbody protection, pipes and hoses (exhaust, fuel system, brakes), rubber elements (gaiters, sleeves, bushes, etc.)	•		•		•		•		•	
Check windscreen and rear window wiper blade position/wear	•		•		•		•		•	
Check operation of the windscreen wiper/washer system and adjust nozzles, if necessary	•		•		•		•		•	
Check cleanliness of hood and boot locks, cleanliness and lubrication of linkage		•		•		•		•		•
Visually inspect conditions and wear of front/rear disc brake pads and operation of pad wear indicators	•	•	•	•	•	•	•	•	•	•
Visually inspect the condition and tensioning of the accessory drive belt(s)			•					•		
Visually inspect the toothed timing drive belt			•					•		
Check engine air cleaner	•	•	•	•	•	•	•	•	•	•
Change engine oil and replace oil filter	(2)									
Replace Transfer Case oil (for AWD versions)						•				

Thousands of miles	12	24	36	48	60	72	84	96	108	120
Thousands of kilometres	20	40	60	80	100	120	140	160	180	200
Years	1	2	3	4	5	6	7	8	9	10
Replace accessory drive belt/s	(3)									
Replace toothed timing drive belt	(3)									
Replace air cleaner cartridge (4)			●			●			●	
Replace fuel filter cartridge (6)			●			●			●	
Change the brake fluid	(5)									
Replace passenger compartment filter (4)	○	●	○	●	○	●	○	●	○	●
Alfa Connect Box system battery replacement (where provided)	(7)									

- (1) Always only use the liquids shown in the handbook for topping up after having checked that the system is not damaged.
 - (2) The actual interval for changing engine oil and replacing the engine oil filter depends on the vehicle usage conditions and is signalled by the warning light or message in the instrument panel. In any case, it must never exceed 2 years. If the car is used mainly on urban routes or it runs on diesel fuel that does not meet the EN590 Specification, the engine oil and engine oil filter must be changed every year.
 - (3) Areas that are not dusty: the maximum mileage is 120,000 km. The belt must be replaced every 5 years, regardless of distance travelled. If the car is used in heavy conditions (dusty areas, particularly harsh weather conditions, very low or very high temperatures for extended periods, urban driving, long periods of idling), the maximum mileage is 60,000 km. The belt must be replaced every 4 years regardless of the mileage.
 - (4) If the vehicle is used in dusty areas, the cleaner should be replaced every 20,000 km.
 - (5) The brake fluid replacement has to be done every two years, irrespective of the mileage.
 - (6) If the car runs on fuel with quality below the relevant European specification, this filter must be replaced every 20,000 km.
 - (7) The battery in the Alfa Connect Box system must be replaced every 5 years, regardless of the mileage.
- Mandatory operations
 ○ Recommended operations

REFILLING

	2.9 V6	2.0 T4 MAir	2.2 JTD	Prescribed fuels and original lubricants
Fuel tank [UK gal/litres]	14/64	14/64	12.7 (58)/ 14 (64) (C)	Unleaded petrol (EN228 specifications) (2.9 V6/ 2.0 T4 MAir)/
including a reserve of [UK gal/litres]	2.1/9.6	2.1/9.6	1.98 (9.0)/ 2.2 (10) (D)	Automotive diesel fuel (EN590 and EN16734 specifications) (2.2 JTD)
AdBlue® reservoir (where provided) capacity approximately [UK gal/litres]	N/A	N/A	3.5 / 16.1	AdBlue® (DIN 70 070 and ISO 22241-1 specifications)
Main cooling system [UK gal/litres]	2.46/11.2	1.93 (8.8)/ 2.02 (9.25) (B)	1.71 (7.8)/ 1.75 (8.0) (E)	50% mixture of distilled water and PARAFLO ^{UP} (A)
Secondary cooling system [UK gal/litres]	1.25/5.75	0.95 (4.3)/ 1.15 (5.25) (B)	1.03/4.7 (E)	
Engine oil filter [UK gal/litres]	-	0.08/0.4	0.11/0.5	SELENIA QUADRIFOGLIO (2.9 V6) / SELENIA DIGITEK PE. (2.0 T4 MAir) / SELENIA W.R. FORWARD 0W-20 (2.2 JTD)
Engine oil sump [UK gal/litres]	-	1.01/4.6	0.85/3.9	
Engine oil sump and filter [UK gal/litres]	1.42/6.5	-	-	
Hydraulic brake circuit [UK gal/litres]	0.2/0.9	0.2/0.9	0.2/0.9	TUTELA BRAKE FLUID TOP EVO
Windscreen washer fluid reservoir [UK gal/litres]	0.92/4.2	0.9/4.1	0.92/4.2	PETRONAS DURANCE SC 35
Automatic transmission [UK gal/litres]	2.01/9.11	2.05/9.3 (AWD) / 2.07/9.4 (RWD)	2.0/9.1	TUTELA TRANSMISSION AS 8
RDU 230-LSD differential [UK gal/litres]	0.25/1.1	0.2/0.9	0.2/0.9	TUTELA TRANSMISSION LS AXLE FLUID
RDU 210/215-LSD differential [UK gal/litres]	N/A	N/A	0.24/1.1	TUTELA TRANSMISSION LS AXLE FLUID
RDU 210-eLSD differential (where provided) [UK gal/litres]	N/A	0.24/1.1	N/A	

	2.9 V6	2.0 T4 MAir	2.2 JTD	Prescribed fuels and original lubricants
AWD System FAD transfer case [UK gal/ litres]	0.09/0.45	0.11/0.5	0.11/0.5	TUTELA TRANSMISSION HYPOIDE GEAR OIL
AWD System TRANSFER CASE [UK gal/ litres]	0.15/0.7	0.15/0.7	0.15/0.7	TUTELA TRANSMISSION TRANSFER CASE

(A) When the vehicle is used in particularly harsh weather conditions, we recommend using a 60% mixture of PARAFLU^{UP} and 40% demineralised water.

(B) With optional original equipment "tow hook".

(C) For markets where provided.

(D) Versions with 14 UK gal / 64 litre fuel tank.

(E) 210 HP AWD versions

N/A = Not applicable

WHEELS

COLD TYRE INFLATION PRESSURES (psi/bar)

When the tyres are warm, the inflation pressure should be + 4.35 psi (+0.3 bar) in relation to the recommended figure. However, recheck the correct value when the tyre is cold.

The pressures given apply to all tyre types: summer, winter and all season (where provided).

2.9 V6

255/45 R20 101Y (front axle): 33.3 / 2.3 (*) / 39.2 / 2.7 (**)

255/40 R21 102YXL (rear axle): 39.2 / 2.7 (*) / 39.2 / 2.7 (**)

285/40 R20 104Y (rear axle): 36.3 / 2.5 (*) / 42.2 / 2.9 (**)

285/35 R21 105YXL (rear axle): 42.2 / 2.9 (*) / 42.2 / 2.9 (**)

2.0 T4 MAir / 2.2 JTD

235/60 R18 107WXL: 2,1 (*) (front axle) / 33.3 / 2.3 (*) (rear axle) or 33.3 / 2.3 (**) (front axle) / 37.7 / 2.6 (**) (rear axle)

235/55 R19 101Y: 2,1 (*) (front axle) / 33.3 / 2.3 (*) (rear axle) or 33.3 / 2.3 (**) (front axle) / 37.7 / 2.6 (**) (rear axle)

255/45 R20 105WXL: 33.3 / 2.3 (*) (front axle) / 36.3 / 2.5 (*) (rear axle) or 34.8 / 2.4 (**) (front axle) / 39.2 / 2.7 (**) (rear axle)

255/40 R21 102WXL: 33.3 / 2.3 (*) (front axle) / 36.3 / 2.5 (*) (rear axle) or 34.8 / 2.4 (**) (front axle) / 39.2 / 2.7 (**) (rear axle)

195/75 18 (space-saver wheel) (where provided): 43.5 / 3.0 (in any load condition) (*) Unladen/medium load inflation pressures (**) Full load inflation pressure

CONNECT

CONTROLS ON TUNNEL

On the central tunnel, fig. 43, there are commands to interact with the Connect system.



43

1212650900EM

- 1: ON/OFF and VOLUME command
- 2: SETTINGS menu activation button
- 3: Rotary Pad
- 4: MENU selection button

WIDGETS

To open the widget, select it using the touchscreen function and then press the widget, or turn the Rotary Pad and then press the widget.

Using the touchscreen function

Select the desired widget or press the "Reorder" (☰) button on the vertical status bar and then:

- ☐ press and hold for a few seconds on the desired widget and move it on the display to the left or right
- ☐ press on the resize icon of the desired widget
- ☐ select the desired widget and then scroll vertically.

Using the controls located on the central tunnel

- ☐ press the "Settings" ⚙️ button on the central tunnel
- ☐ turn the Rotary Pad to select the "Settings", fig. 44
- ☐ press the Rotary Pad to confirm the selection and then select one of the following items: "Reorder widget"/"Resize widget"/"Widget content"
- ☐ select desired item



44

12126S0906EM

Viewing widget contents

- ☐ Turn the Rotary Pad to select the desired widget and then press the Rotary Pad to confirm the selection
- ☐ turn the Rotary Pad to display the contents of the widget and then press the Rotary Pad to keep the display active and exit the widget

RADIO (TUNER) MODE

SRC: select to select the required frequency band

- ★ to select the Favourites list
- ☰ to view the list of available radio stations
- 🔊 to manually seek a radio station

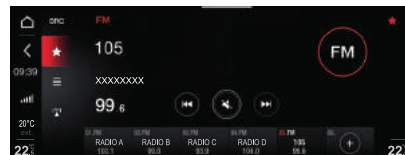

45

12126S0926EM

MEDIA MODE

Press the graphic button to activate "MEDIA" mode SRC: the display shows the available sources: AM, FM, DAB, **Bluetooth**®, USB1, USB2.

SRC: activate the list of sources

- ⇄ to activate Shuffle/Playback Mode
- 📖 to activate Tracks Library
- 📌 to activate the Playlists

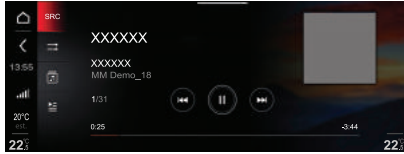



46

1212650937EM

PHONE MODE

Pairing a mobile phone

Proceed as follows:

- activate the **Bluetooth**® function on the device
- in the main menu that can be activated by pressing button  on the central tunnel, select the "Settings" function
- select "Infotainment"
- select "Phone" and then "Bluetooth Settings"
- select the **Bluetooth**® device
- select "Add Device" 
- search for the Connect system on the **Bluetooth**® audio device
- select the device to be paired

- when requested by the audio device, enter the PIN code shown on the system display or confirm on the device the PIN displayed
- if the pairing procedure is completed successfully, a dedicated screen will appear.

The **Bluetooth**® function can also be activate by pressing the "OPTIONS" button in the "PHONE" or "MEDIA functions" which can be selected on the main menu.

NAVIGATION MODE

(where provided)

Setting a destination

To set a new destination, select the graphic button  (using the "touchscreen" function or by rotating the Rotary Pad): the graphic keyboard for entering the destination address will appear on the display and the list of "Destinations" will appear on the right side.

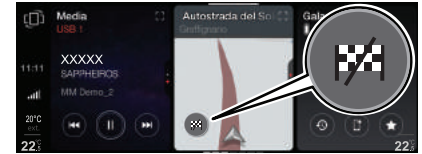

47

1212652010EM

SETTINGS

The following items are available in the menu:

- "Lights"
- "Units & Language"
- "Clock & Date"
- "Passive Safety"
- "Convenience & Comfort"
- "Doors & Locks"
- "Cluster"
- "Infotainment"
- "System"

PERFORMANCE

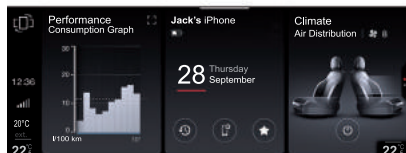

48

12126S0400EM

The main screen shows information about:

- "Technical gauges"
- "Consumption history"
- "Efficient Drive"
- "Engine torque"
- "Temperatures" (Quadrifoglio version only)
- "Drag Race" (Quadrifoglio version only)
- "Performance content" (where provided)

CAR INFORMATION

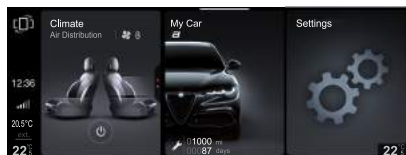

49

12126V2305EM

The main screen shows information about:

- Service (scheduled servicing)
- TPMS (Tyre Pressure Monitoring System)
- Engine oil level
- AdBlue® level (only Diesel versions) (where provided)
- Alfa DNA™ system

ALFA CONNECT SERVICES

(for versions/markets where provided)



OFFICIAL TYPE APPROVALS

RADIO EQUIPMENT

All radio equipment provided with the car complies with the 2014/53/EU directive, UA.RED.TR, the French SAR Decree Law dated 15/11/2019 and the UKCA (UK Conformity Assessed) Certification dated 01/01/2021 in force in the United Kingdom.

For more information go to www.mopar.eu/owner or <http://aftersales.fiat.com/elum/>

RADIO FREQUENCY DEVICES

All radio frequency devices comply with the regulations in force in the countries in which they are sold.

For more information go to www.mopar.eu/owner or <http://aftersales.fiat.com/elum/>



La meccanica delle emozioni